

46" Outdoor Freestanding Digital Poster

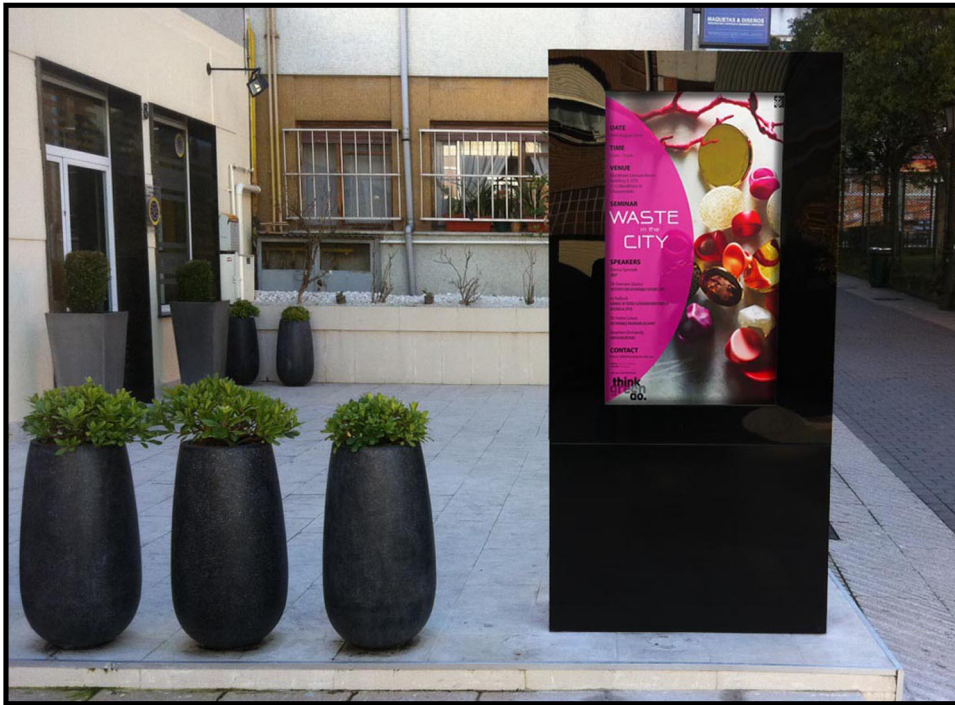

24/7 usage



high definition



multiple inputs



wide viewing angle



temperature control



high brightness



lock protected compartment



image, video & music



vandal proof



weatherproof

These dynamic Outdoor Freestanding Digital Posters can be used in any outdoor conditions. The brand new range of outdoor units are designed with a robust outer casing to give protection from both the elements and the public.

Temperature is an important matter with regards to outdoor digital signage, not only must the screen be able to withstand hot and cold surroundings but it must be able to manage internal conditions optimising the working temperature. A built in air-conditioning system is tailored to allow the display to work at an optimal level in any climate.

Other factors to consider are dust, debris and moisture from the air entering and affecting the performance of the screen. The outer casing keeps out all airborne swarf, dust and other particles; broadening the range of possible environments. The outer cases have a IP65 waterproof protection, meaning they are protected from any wet weather conditions.

Brightness is key when using outdoor digital signage, our Outdoor Freestanding Digital Posters are 1500 cd/m², more than 3 times brighter than a standard home TV.

Another advantage of this innovative marketing medium is how easily it can be updated. Traditionally outdoor signage was costly as technicians had to change and maintain signs whereas digital signage can be updated easily and remotely if required, lowering running costs further and increasing the return on the investment.

An eco-friendly power timer allows the user to set what time the display turns on and off during a week. This means that your overall power consumption will be conveniently reduced as the display will not be running when it is not required.

Some examples of suitable environments for this range include train/bus stations, town centres, concert halls, theatres, sporting arenas and outdoor leisure centres.

"These contemporary outdoor displays are designed with protection in mind - from both the elements and the public."

46" Outdoor Freestanding Digital Poster

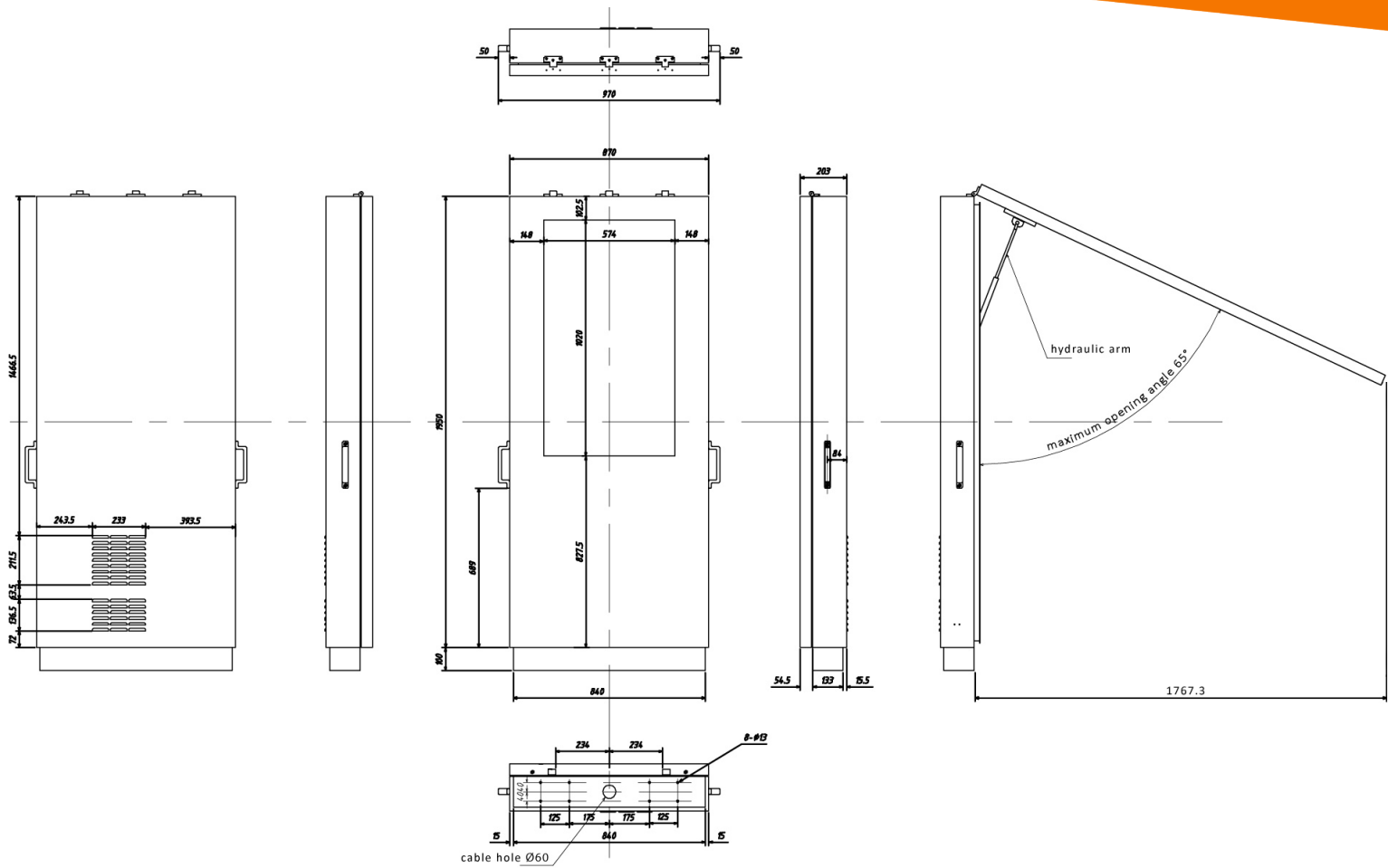

46" Outdoor Freestanding Digital Poster	
Display Size	46 Inch
Resolution	1080x1920
Display Area (mm)	574x1020
Aspect Ratio	9:16
Unit Size (WxHxD mm)	870x1950x203
Net Weight (kg)	150
Brightness (cd/m ²)	1500
Colour	16.7M
Viewing Angle	178°
Contrast Ratio	3000:1
Power Consumption with Air Concitioning Off (W)	500
Power Consumption with Air Concitioning On (W)	2000
Input Voltage	AC110~240V(50Hz~60Hz)
Working Temperature	-20 °C to 60 °C
Audio	5W, 8Ω
Input Ports	VGA, AV, HDMI, YPbPr
Accessories	Remote control, AC Power Cable, Scheduling Software CD, Key, User Manual

"These contemporary outdoor displays are designed with protection in mind - from both the elements and the public."